

AFRL

THE AIR FORCE RESEARCH LABORATORY
LEAD | DISCOVER | DEVELOP | DELIVER



CubeFlow Overview

11 June 2009

Outline

- **SPA primer (to define/calibrate the terminology)**
- **Cubesat 101 (even briefer overview)**
- **SPA + CubeSat = Fun (how we map SPA into CubeSats)**
- **Current status**

SPA: The Key Concepts

- 1. Push-button toolflow (PBTF)**
- 2. Self-describing components (XTEDS)**
- 3. Interface modules for SPA conversion (ASIM)**
- 4. Self-organizing/self-integrating networks (SPA-U, SPA-S, SPA-10, SPA-W,...)**
- 5. Service-oriented software engineered for reuse – the satellite data model (SDM)**
- 6. Improved testability (“test bypass”)**

1. Push-button Toolflow

Mission Goals and Requirements

Component Capabilities

2.

SPACE-CRAFT PROFILER

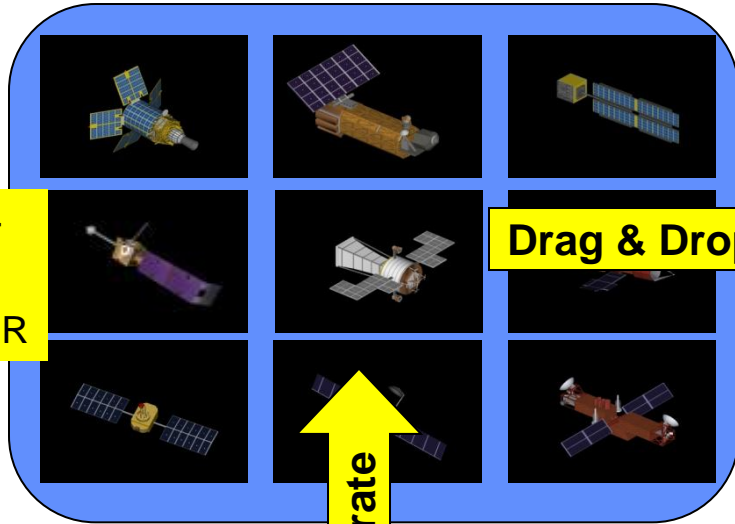

Drag & Drop Design

Iterate

1.

MISSION CAPTURE

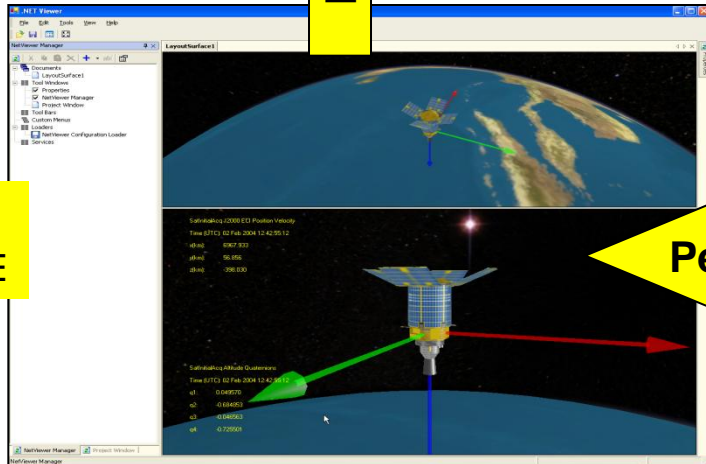

Performance Modeling

Component Capabilities

Component Icons

Connections

3.

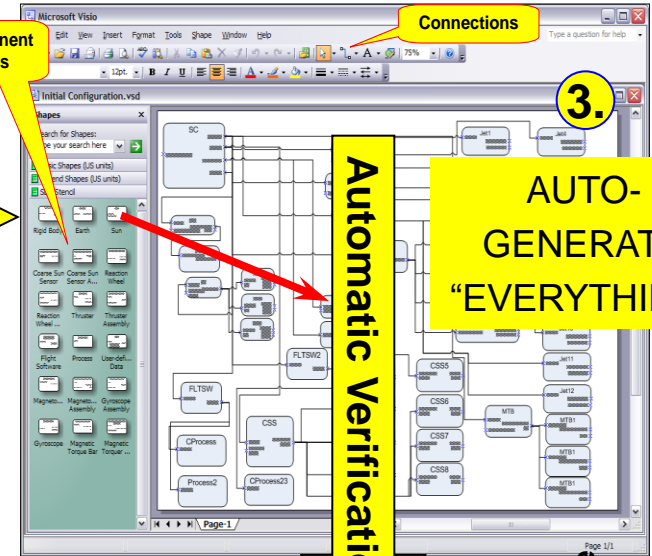

Automatic Verification

AUTO-GENERATE "EVERYTHING"

4.

COMPARE SIM VS. THE ORIGINAL MISSION

```

* CATEGORY RULES
.....
predCategory( catidReferenceFrame ).
predElementOf( catidReferenceFrame, catidReferenceFrame ).

predCategory( catidCoordinateSystem ).
predElementOf( catidCoordinateSystem, catidCoordinateSystem ).

.....
* COMPONENT RULES
.....
predComponent( clsidCE
predElementOf( clsidCE
predElementOf( clsidCE
fncln( iidEnvironmentOb
    
```

Design Verification Rules Engine

2. Electronic Datasheets: the eXtended Transducer Electronic DataSheet (XTEDS)

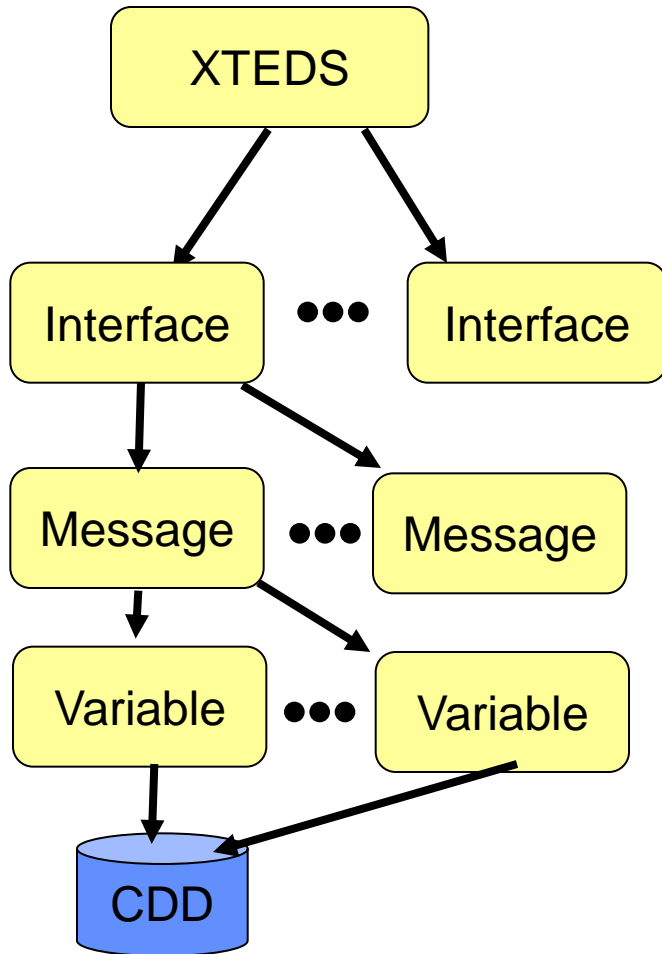

- **Primary mechanism for self-description**
 - Embedded in hardware and software applications
 - Describes “knobs” and “measurands”
- **Conveys “semantic precision” through a common data dictionary (CDD)**
- **Enforces order in the “LEGO universe” of SPA (features only exist if known through XTEDS)**

3. Intelligent Modules for Plug-and-play: The Applique Sensor Interface Module

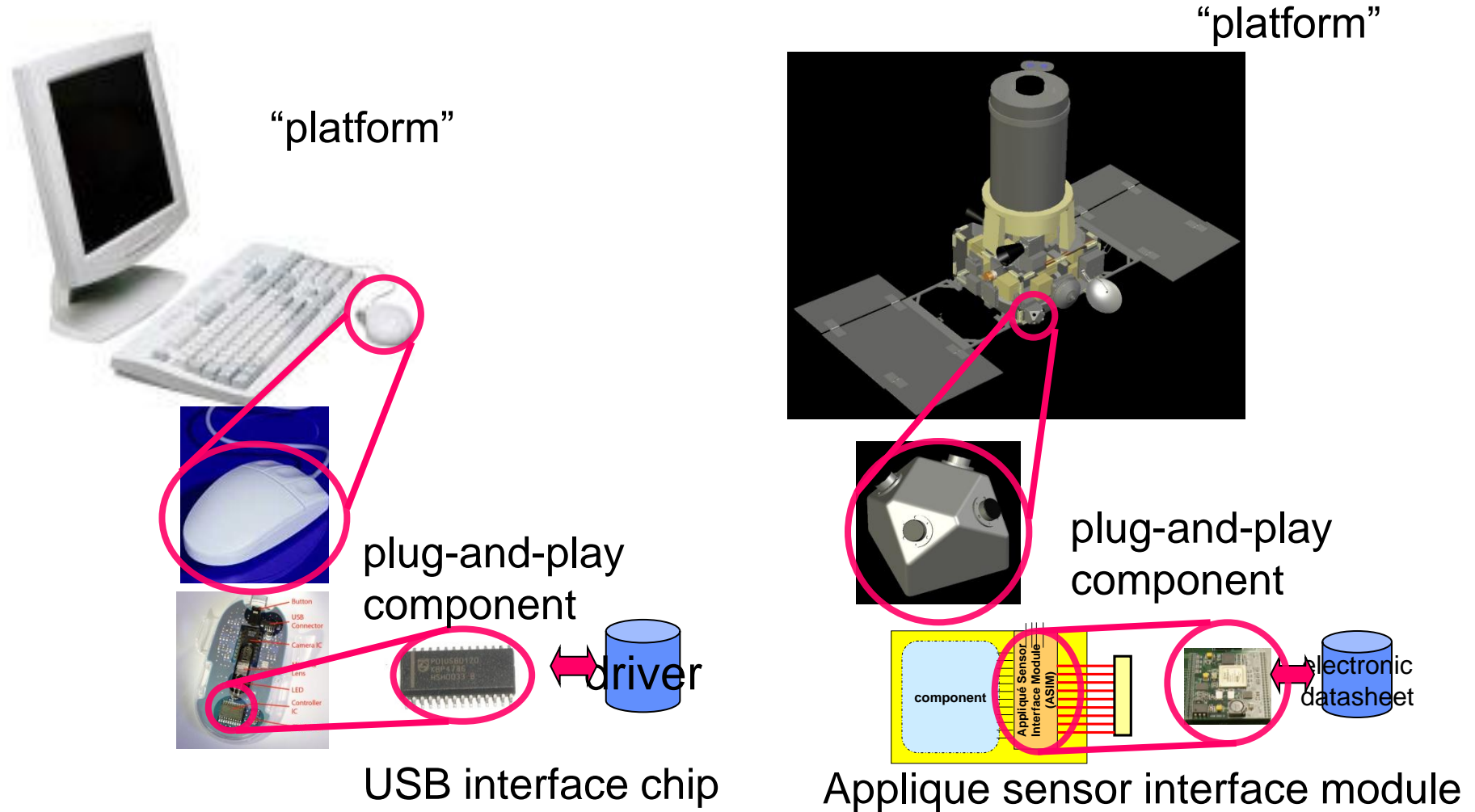

4. Self-Organizing Networks

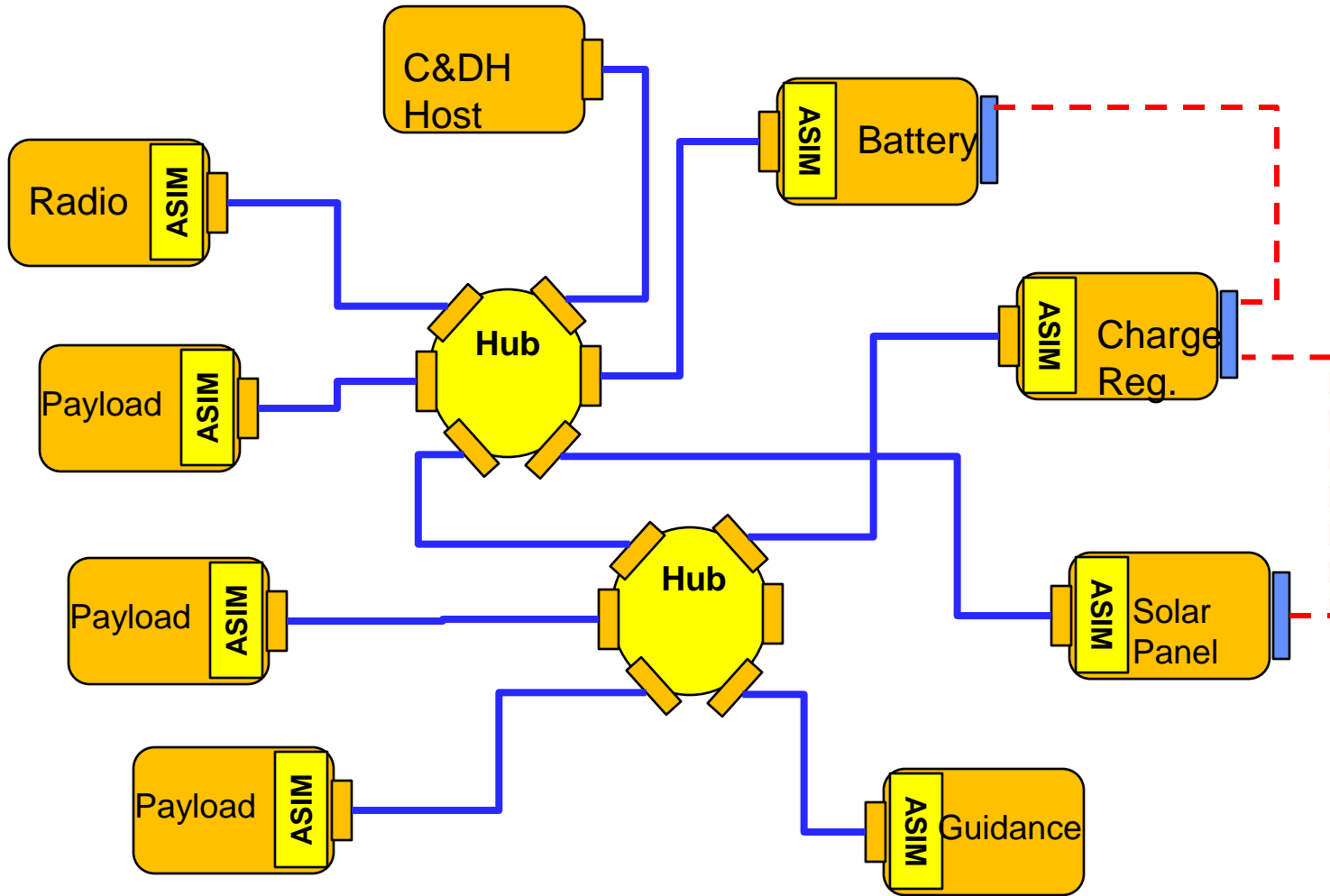

5. The Satellite Data Model (SDM) Building Awareness into Plug-and-play

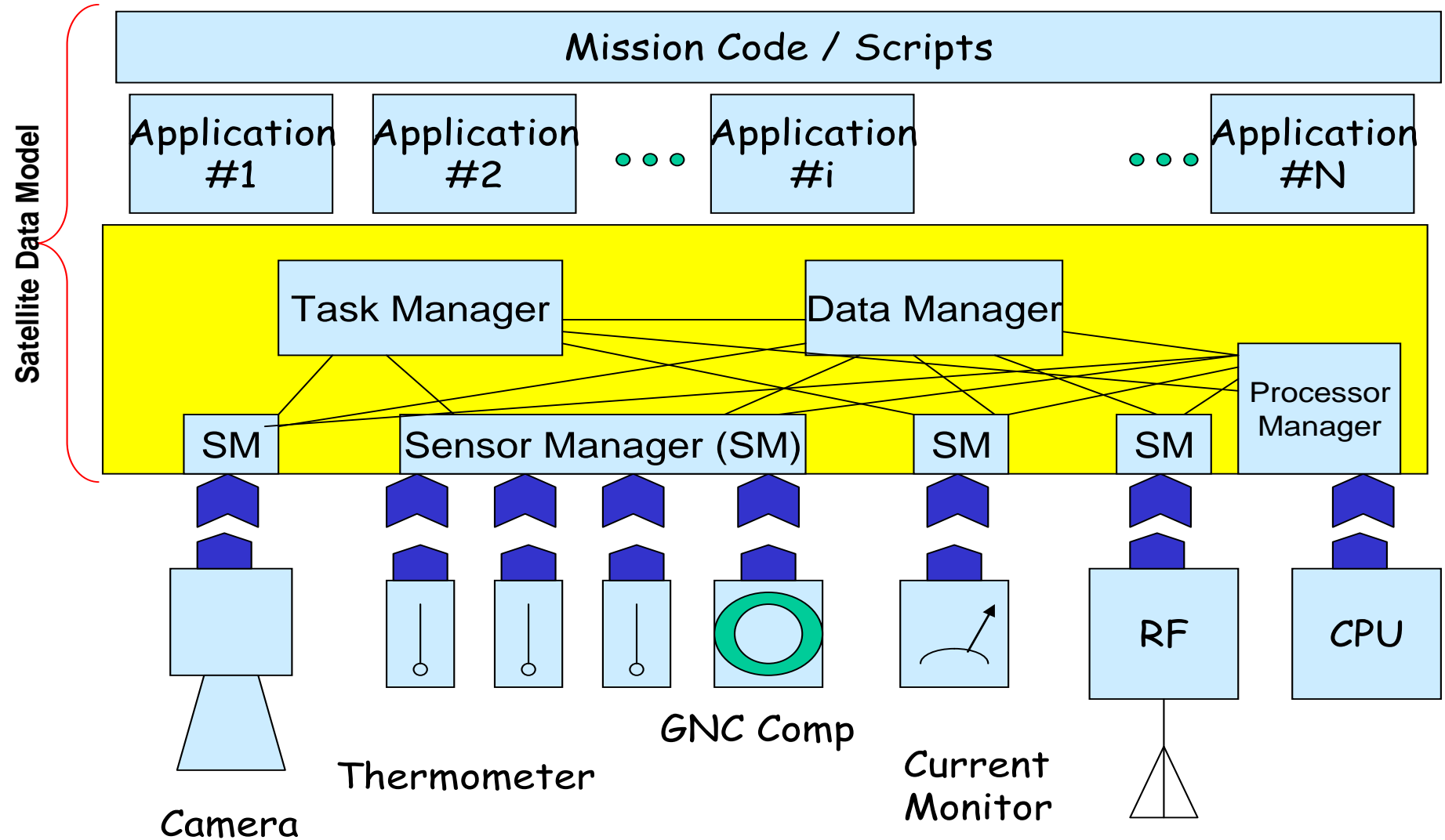

Merging CubeSats with Plug-and-play “ NanoSPA ”

- **Goal of this AFRL work is to break “Swiss watch” effect and promote interchangeability of components between different development groups**
- **More than that, we want plug-and-play components**
- **The advent of a “table-top” satellite that could be as easily integrated as a personal computer.**

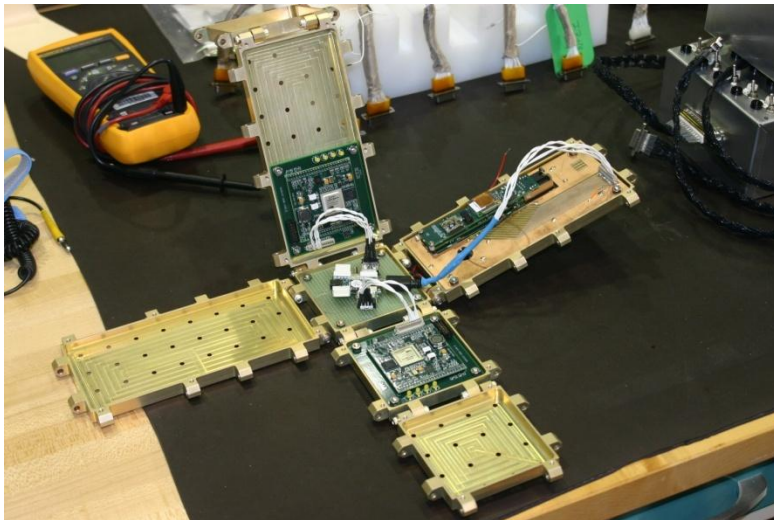

If Eli Whitney were building satellites, we think they'd be this way

Summary of Initial Work

- **Timeframe: Summer 2008 (June-Sept)**
- **Team: AFRL staff, students, industry**
- **Inspiration was to do “Chileworks” with CubeSats**

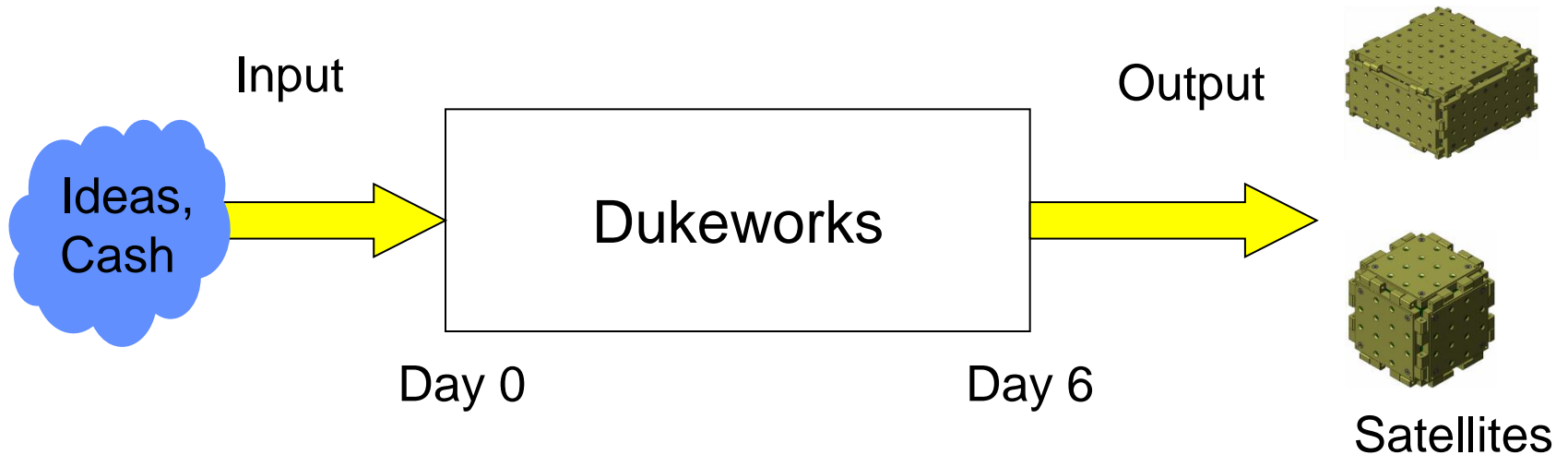

“nanoSPA” Elements

- **Structural approach**
- **Power management and distribution**
- **Avionics**
- **Software – no modifications (!)**
- **GNC**
- **Payload**
- **CubeFlow – toolflow to construct nanoSPA components and systems**

NMF Facet Family

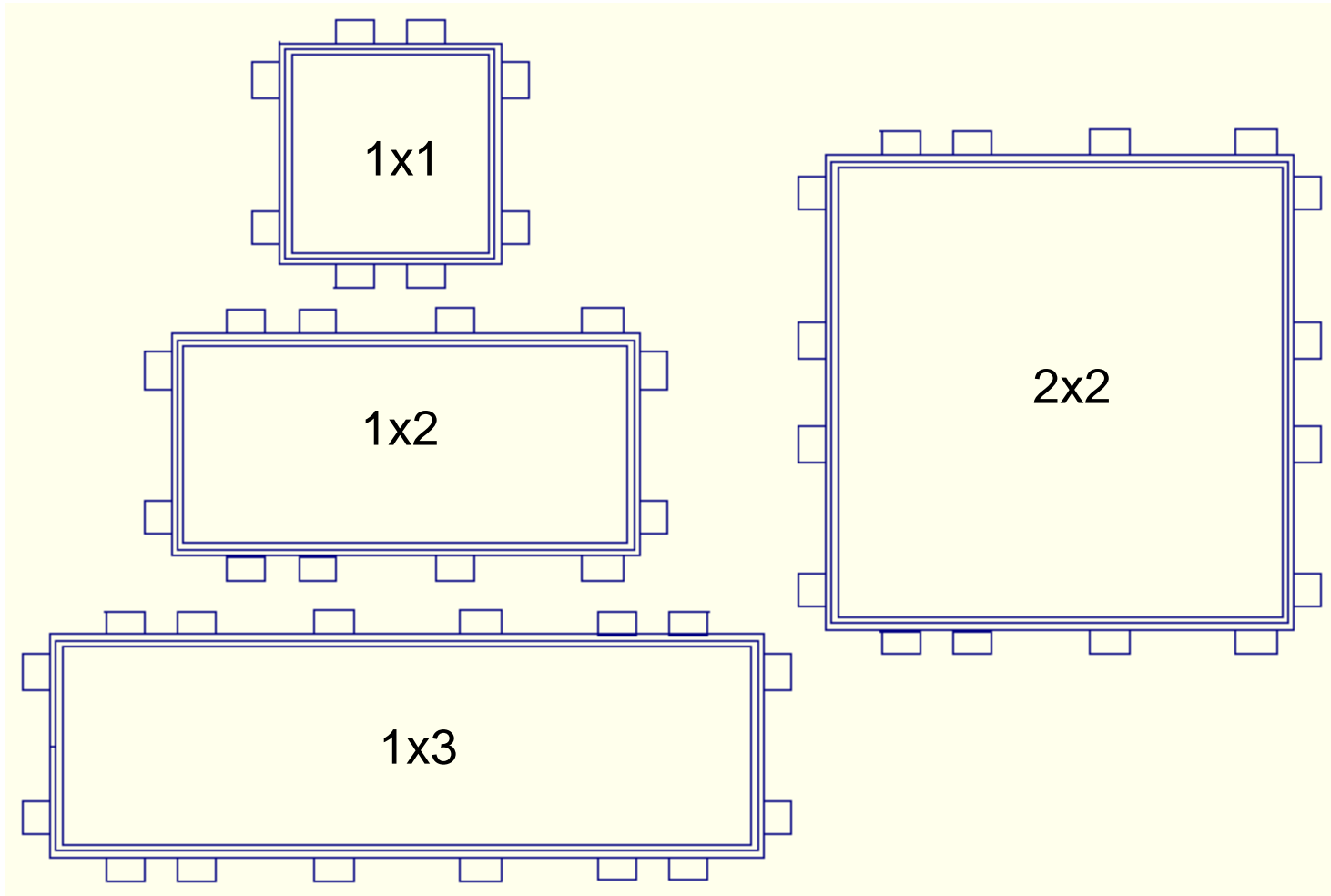

Power Subsystems

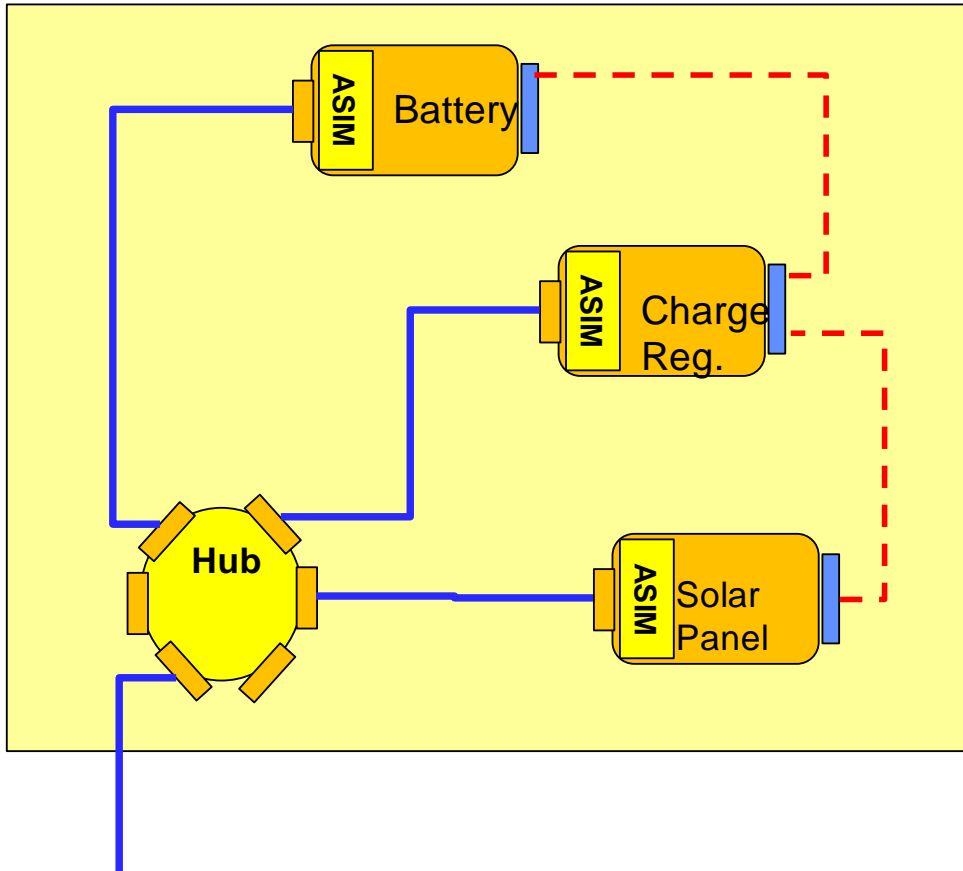

- Power subsystems targeted for nominal 5V output
- Can be realized as modules of separated elements or in tightly coupled configurations

Avionics Approach

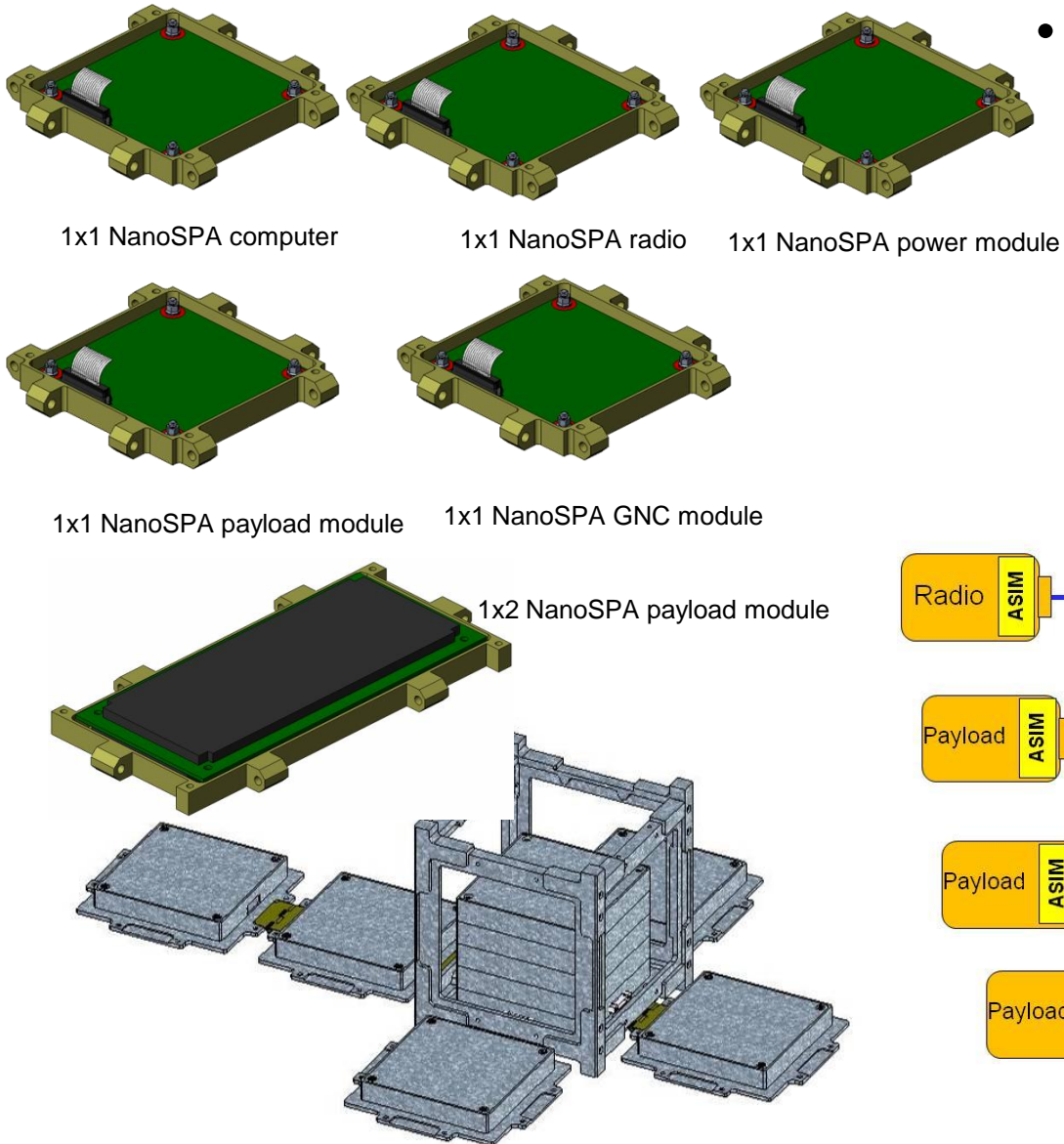

- Using Space PnP avionics (SPA) approach, cubes can be decomposed into self-describing components, just as in PnP Sat

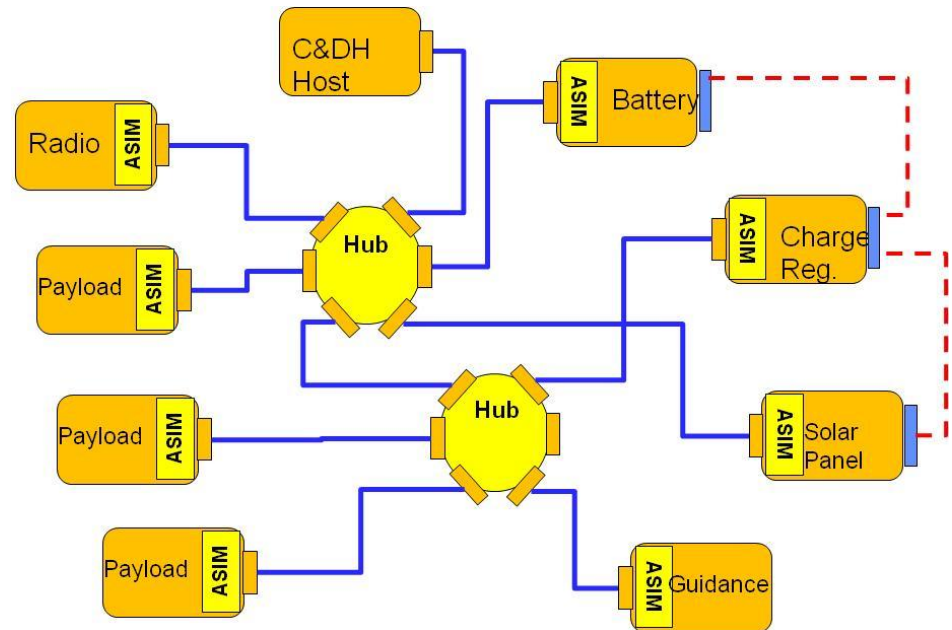

Radio Modules/Comm Architecture

Example radio options

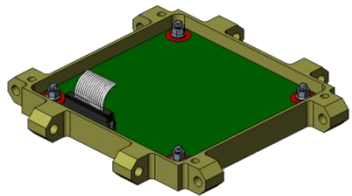

Radio Approach #1
802.11b (testing)

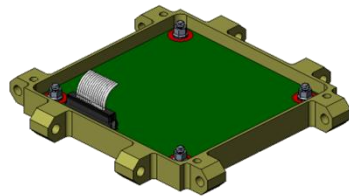

Radio Approach #2
Amateur radio

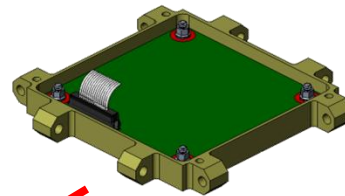

Radio Approach #3
TDRS transponder
(In Phase 1
Development)

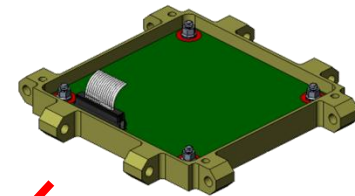

Radio Approach #4
Unified PnP radio

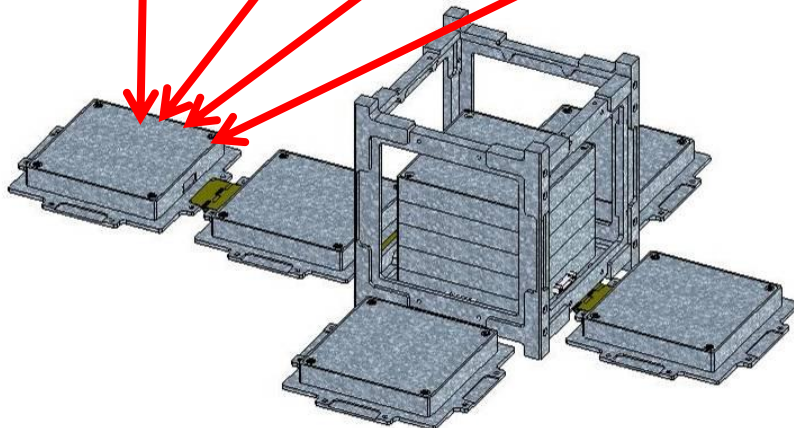

Ideally, radios should be “PnP” like the internet connection on your laptop. Goal is to have radio modules interchange without rewriting system software.

A Web-based tool flow!?

Drupal CMS distributed CubeFlow

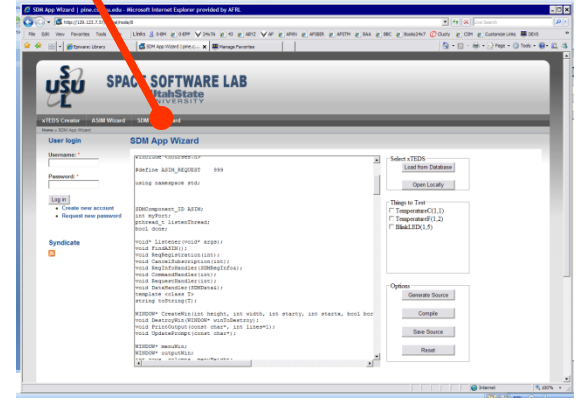
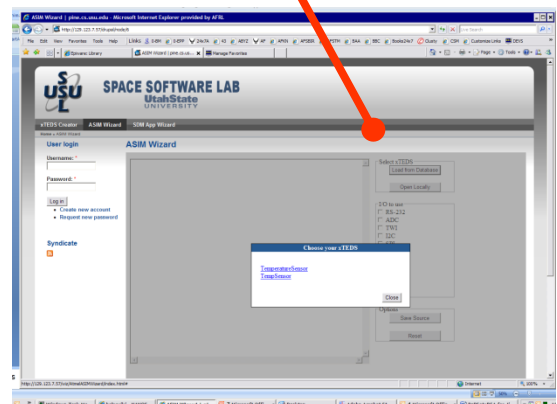
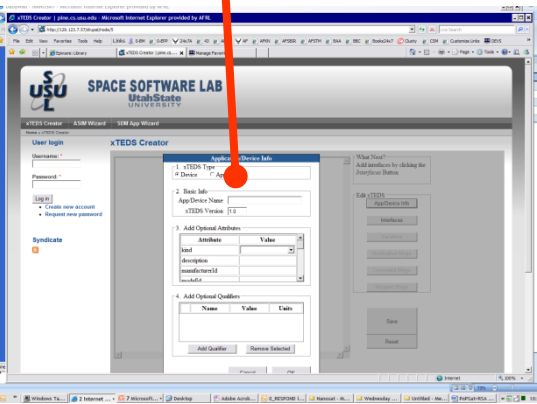
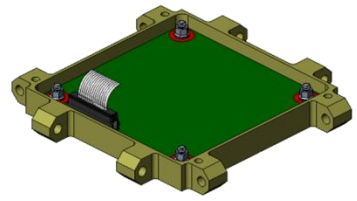
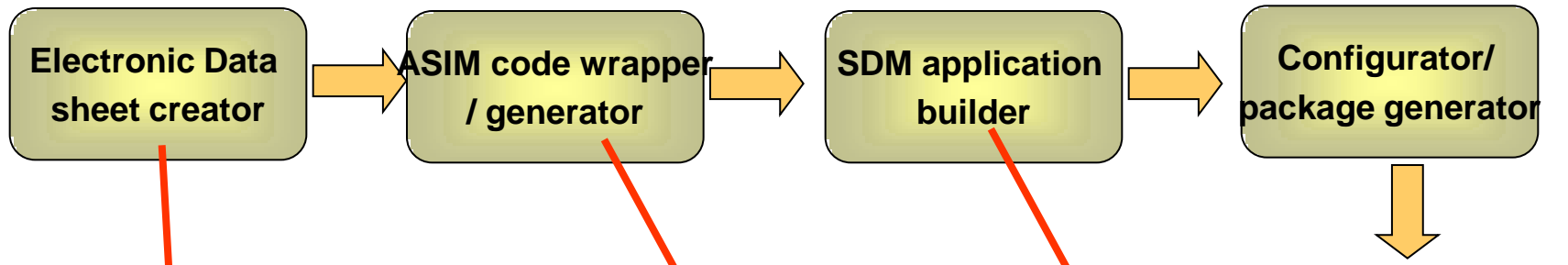

Replace “Design by Committee” by “Design with Community”

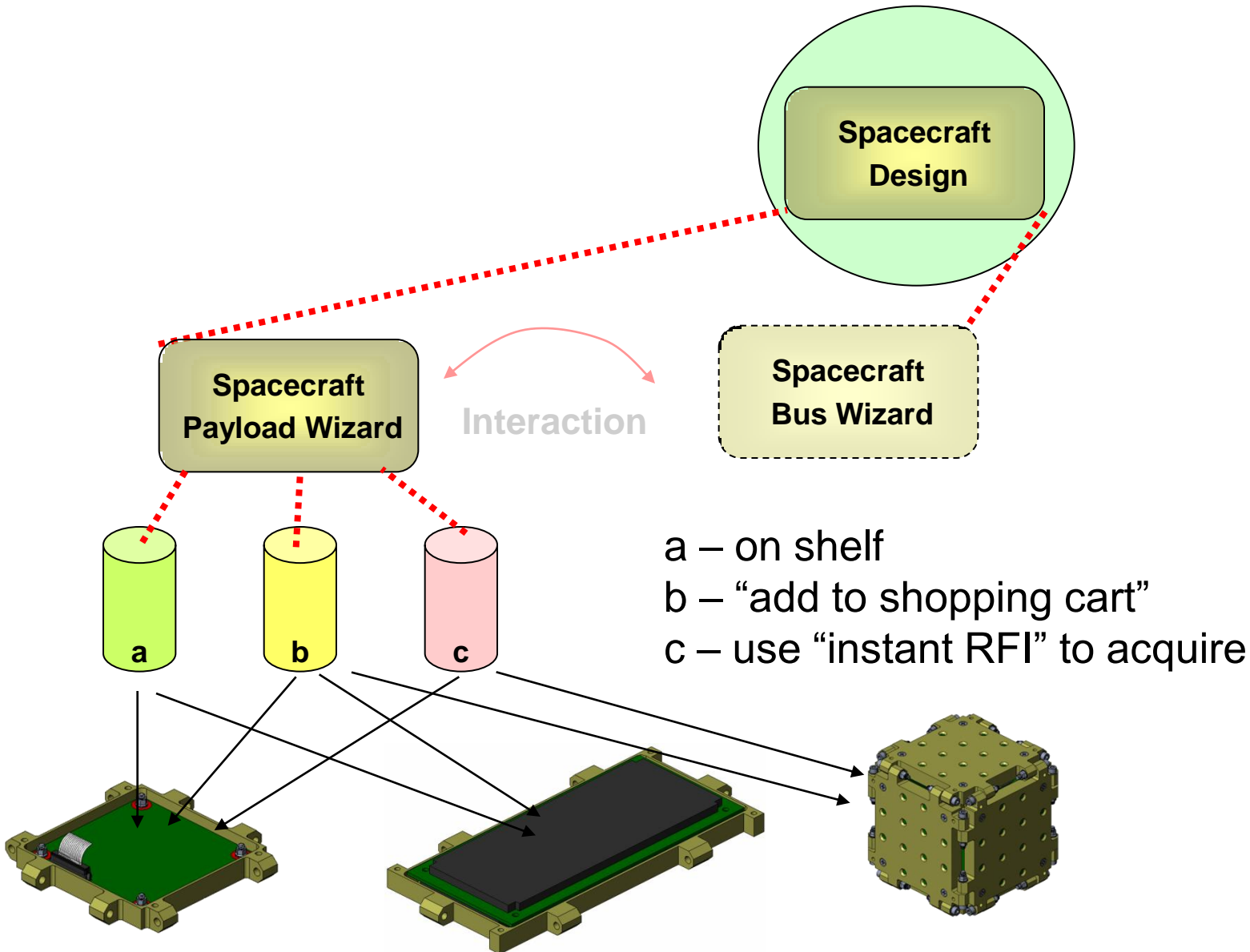

Demonstration Hardware

1x1x1 Configurations

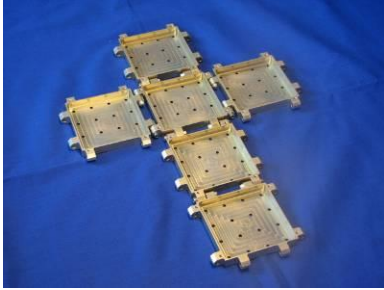

FlatSat

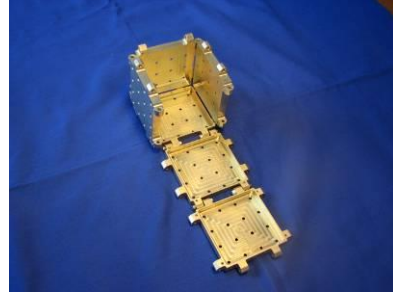

Partially Assembled



Assembled



Exterior Module

1x1x2 Configurations

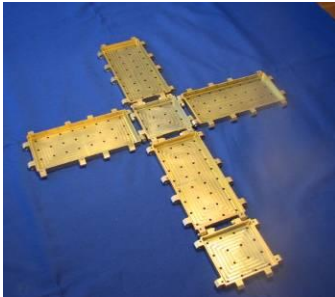

FlatSat



Partially Assembled



Assembled



Exterior Module

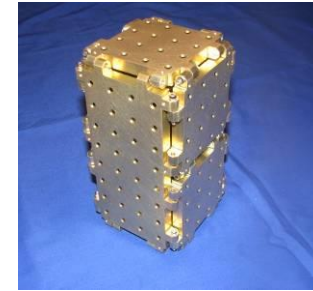

(2) 1x1 Panels

Other Configurations

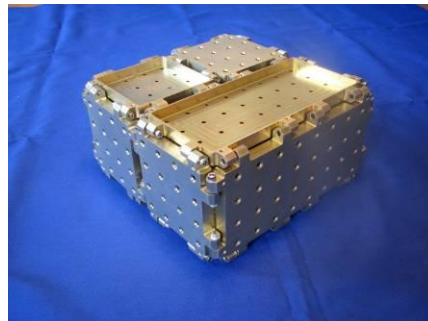

1 x 2 x 2 with Interior and Exterior Modules

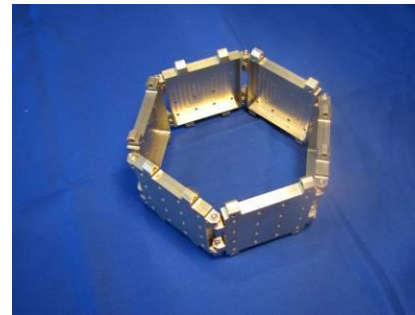

Hexagonal Cross-section

nanoSPA Demo Configuration

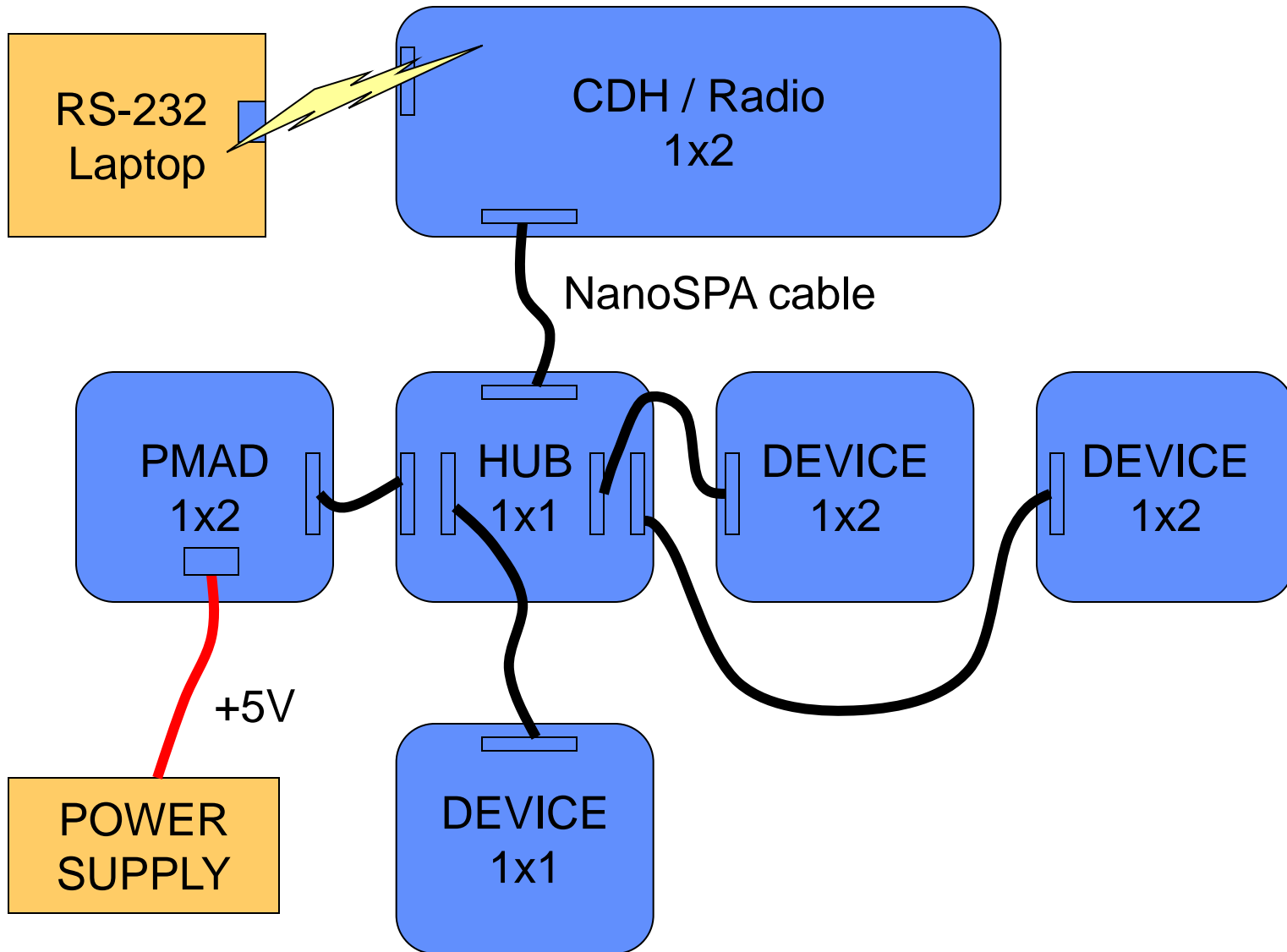

Demonstration System

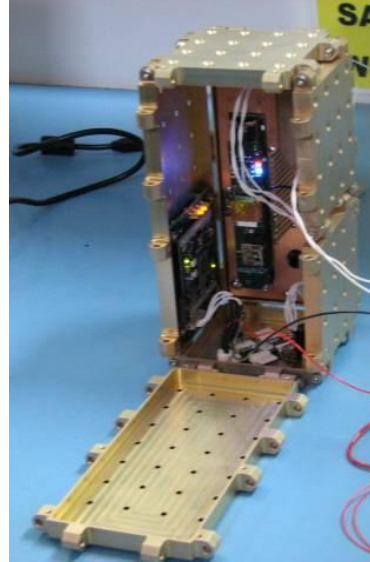
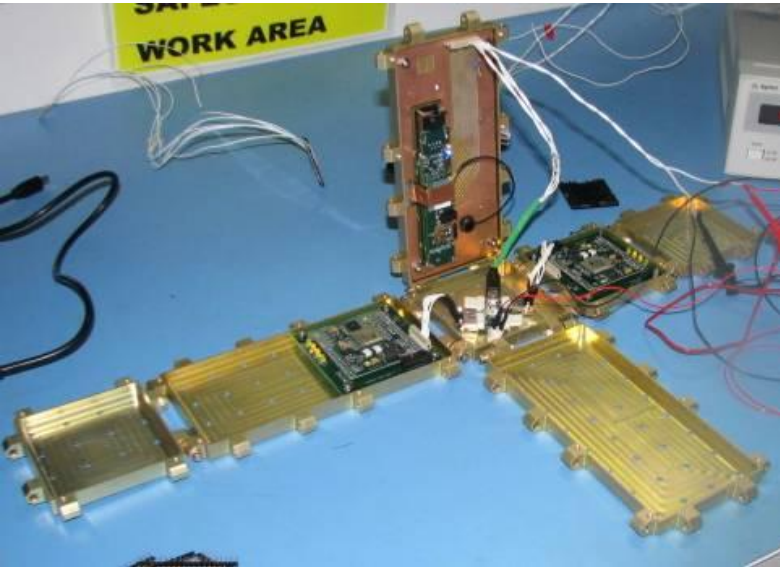

- Operation of fully functional SPA network demonstrated in 1U and 2U configurations (2U shown)
- 802.11 used as placeholder for RF system

Works in Progress for 2009

- **Reduced size, weight, and power ASIM in development**
 - Prototypes (electrical, not form factor) developed
- **Integrated C&DH / hub designed for 1x1 in development**
- **SPA-U to SPA-S gateway in development**
- **Test bypass needed, not on fast track however**
- **Power subsystem work is in progress**
- **Work ongoing to refine concepts of the CubeFlow web-based integrated design environment**

Work in progress: ASIM shrinks

- nanoSPA networks consist of host, hubs, and nanoSPA devices (endpoints)
- New ASIM concepts have been developed
 - Electrical prototypes (non-miniaturized) in test
 - Target form factor for miniaturized version (1.3x1.3x0.65 cm)

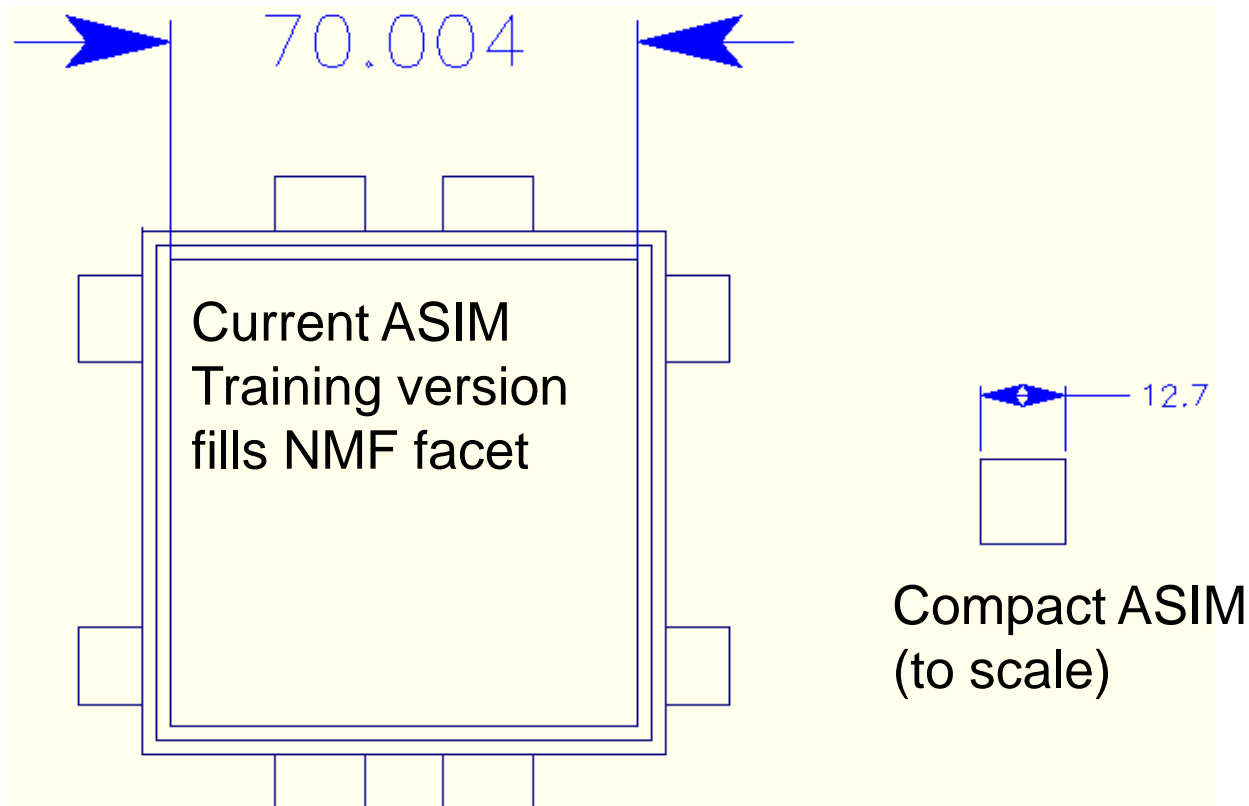

Work in Progress: C&DH Upgrades

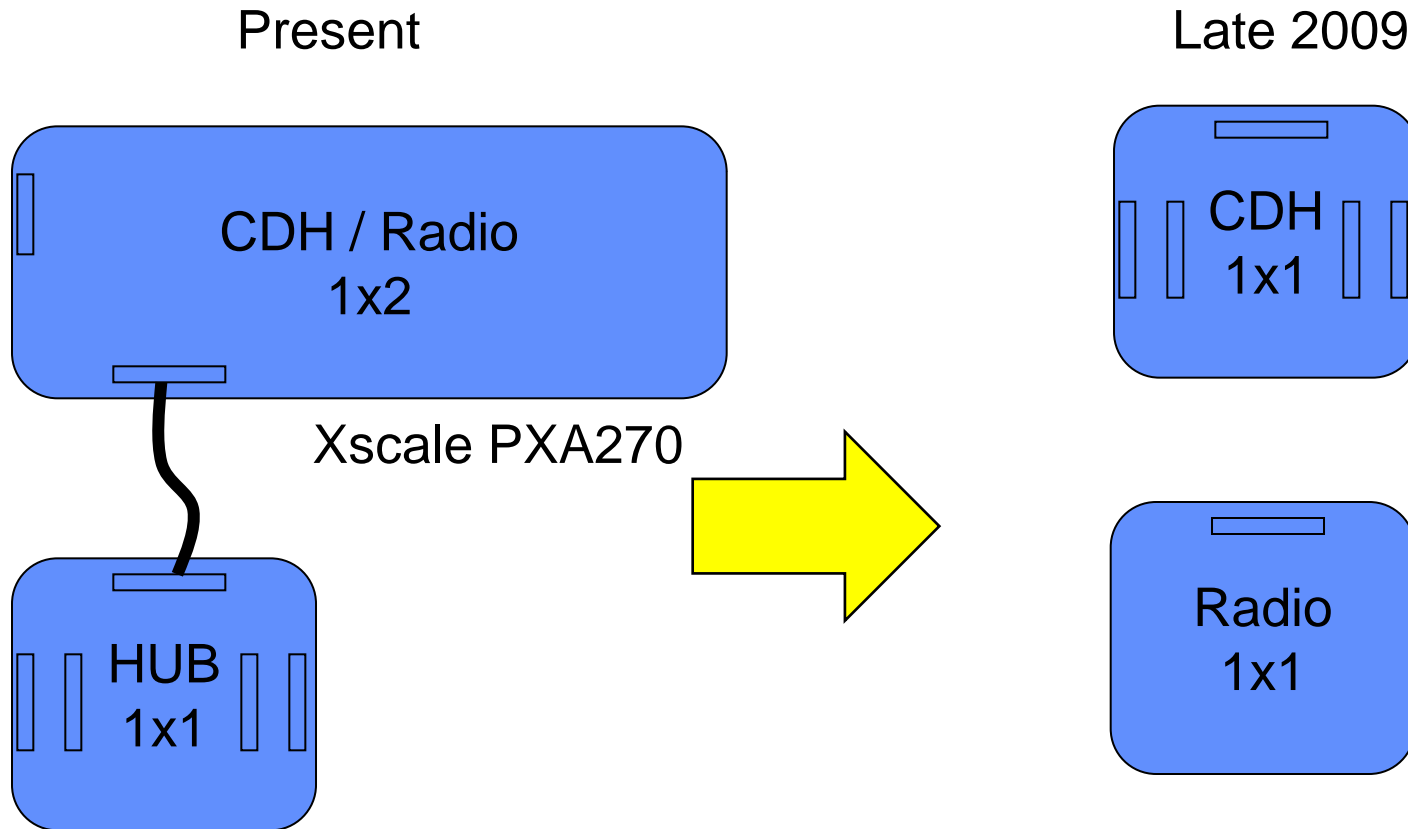

Work ongoing to split Radio and C&DH into separate modules, integrating hub (33% reduction in size), simplify interchange of radio modules (independent of C&DH)

Nano-C&DH

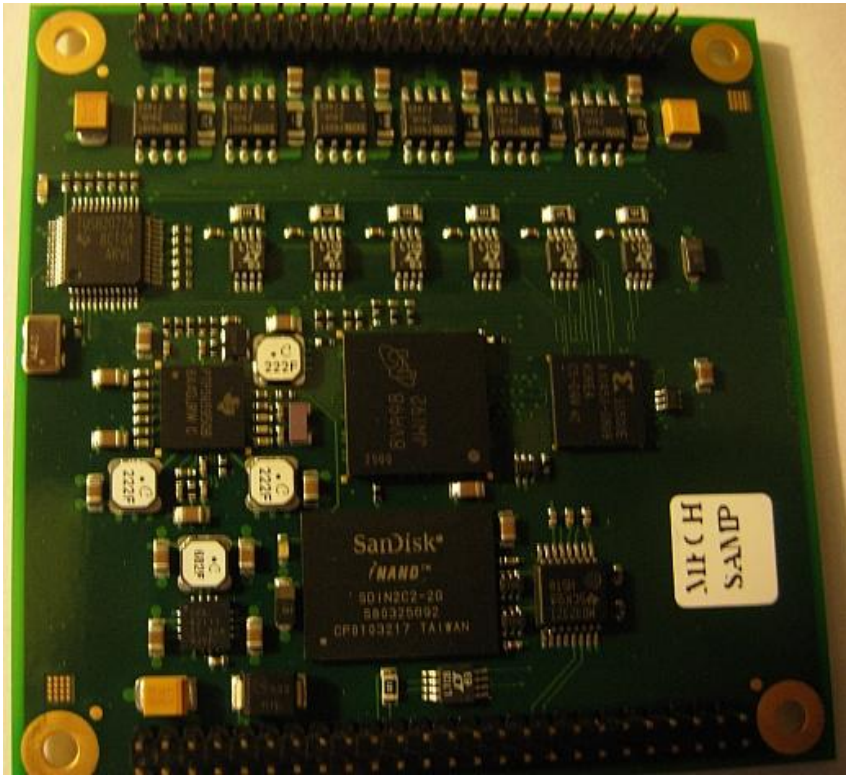

- **OMAPs (TI digital signal processor) based in very compact form (70x70x12.5mm)**
- **Full Linux capability**
- **Six SPA-U ports**
- **Under development by Data Design Corporation through SAIC subcontract to USAF**

Work in Progress: SPA gateway

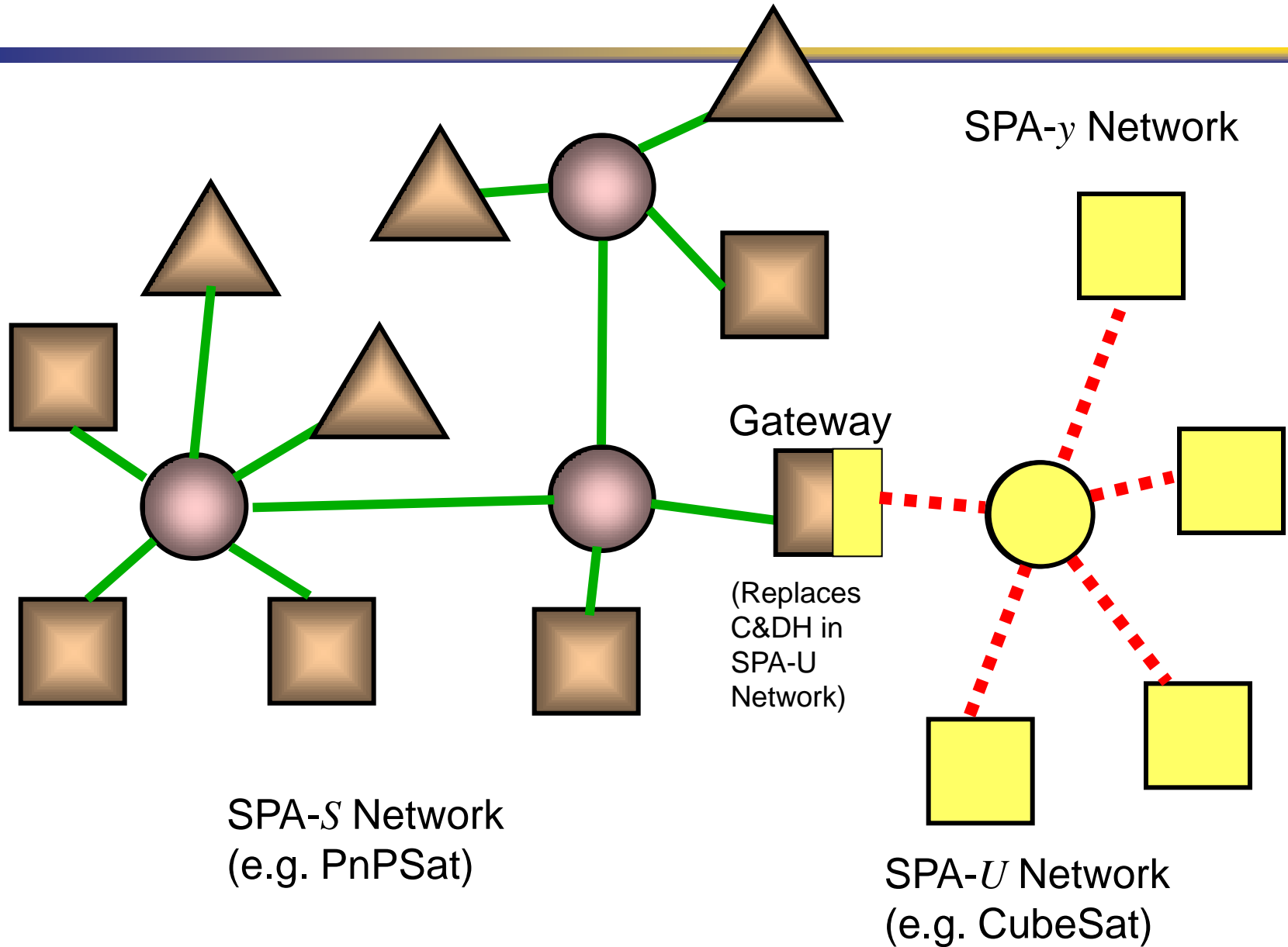

Now what?

- **Three more classes planned**
 - August, August, October
- **Developing simpler versions of CubeFlow**
- **Developing web infrastructure to support a community of users**
- **Trying to figure the way ahead**
 - Many ideas, not experienced with this kind of outreach
 - Could use some help?